

ROTAPANEL

XXL-ProPanel HD/LCD

THE PROFESSIONAL LARGE-SIZE HIGH DEFINITION LCD SCREENS

ROTAPANEL, THE SPECIALIST IN LARGE-SIZE HD/LCD SCREENS

XXL-Propanel HD/LCD catches-and-holds your attention by amazing high resolution quality images, animations and movies.

Displays images, video clips, cartoons, textual tickers/scrolls, RSS feeds, live events, flash cartoons, attached Power Point, PDF, documents, audio play lists, internet sites (depending on type of optional CMS).

High definition 65" up to 82" free standing and wall mounting

Modular built for simple and fast service. Secure in public environments. Vandal resistant.

65" up to 82" extendable front for easy maintenance access

Rotapanel has experience with many different Content Management Systems (CMS). We are happy to supply you with a suitable Media Player which fits your needs or we will implement your own CMS. Compatible with all digital signage software products.

The best and most flexible indoor signage for: **shopping malls**, airports, **cinemas**, railway stations, **bus terminals**, subways, **convention centers**, sport arenas, **gas stations** etc.etc.

XXL-Propanel HD/LCD screens guarantee a long-life carefree operation.



Rotapanel International

is one of the world's leading players for in- and outdoor advertising for over 45 years! Rotapanel is delivering its products in over 80 countries, not only for the advertising industry but as well for the traffic market. In house production by means of CNC 'state-of-the-art' machinery and welding robots. Rotapanel: Your strong and reliable long term partner for the future!

ROTAPANEL

www.rotapanel.com

ROTAPANEL

XXL-ProPanel HD/LCD

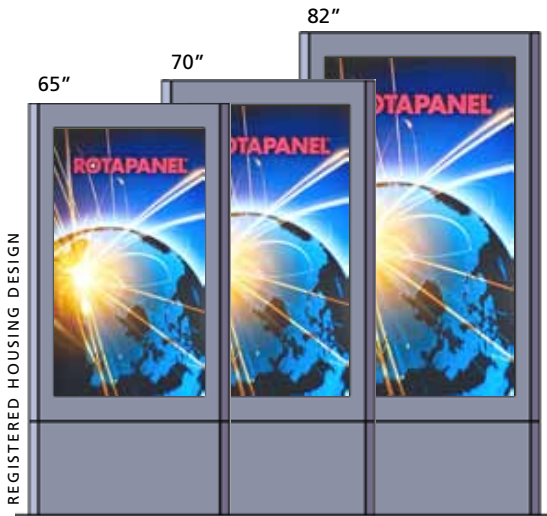

General information professional TFT LCD indoor advertising displays

Display	65" Full HD	70" Full HD	82" Full HD
Diagonal Size	65" (165 cm) diagonal	70" (178 cm) diagonal	82" (208 cm) diagonal
Aspect Ratio	9:16 portrait	9:16 portrait	9:16 portrait
Resolution	1080x1920 pixels	1080x1920 pixels	1080x1920 pixels
Brightness	700 cd/m ² (typical)	600 cd/m ² (typical)	600 cd/m ² (typical)
Contrast Ratio	2.500:1 (typical)	2.000:1 (typical)	2.000:1 (typical)
Number of colors	16,7 Mil	16,7 Mil	16,7 Mil
Response time	8 ms	8 ms	8 ms
Viewing angle	178° in all directions	178° in all directions	178° in all directions
Display Area (portrait)	803 mm x 1428 mm (WxH)	871 mm x 1549 mm (WxH)	1015 mm x 1805 mm (WxH)
Backlight type	CCFL	CCFL	CCFL
Vandal proof housing:			
Cabinet	aluminium	aluminium	aluminium
Surface treatment	powder coated	powder coated	powder coated
Glass	6mm tempered safety glass	6mm tempered safety glass	6mm tempered safety glass
Weight wall model	122 kg	132 kg	162 kg
Weight single sided freestanding model	200 kg	210 kg	250 kg
Operating Parameters:			
Operating Temperature	0°C to +30°C / +35°C (optional)	0°C to +30°C / +35°C (optional)	0°C to +30°C / +35°C (optional)
Power Supply	AC 100-240 V, 50/60 Hz	AC 100-240 V, 50/60 Hz	AC 100-240 V, 50/60 Hz
Power Consumption	550 Watt	650 Watt	1000 Watt

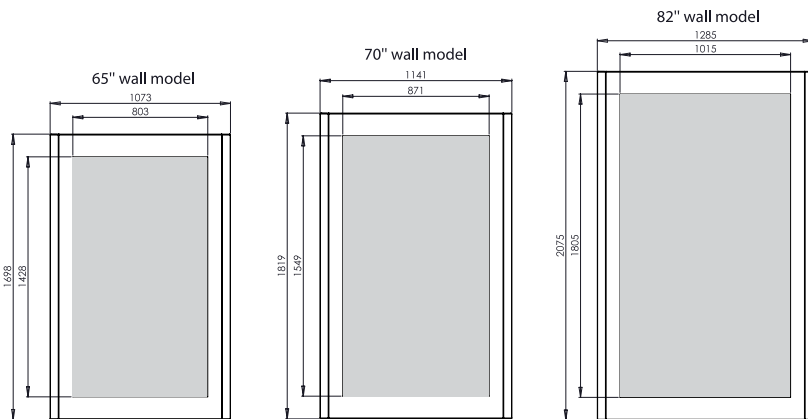
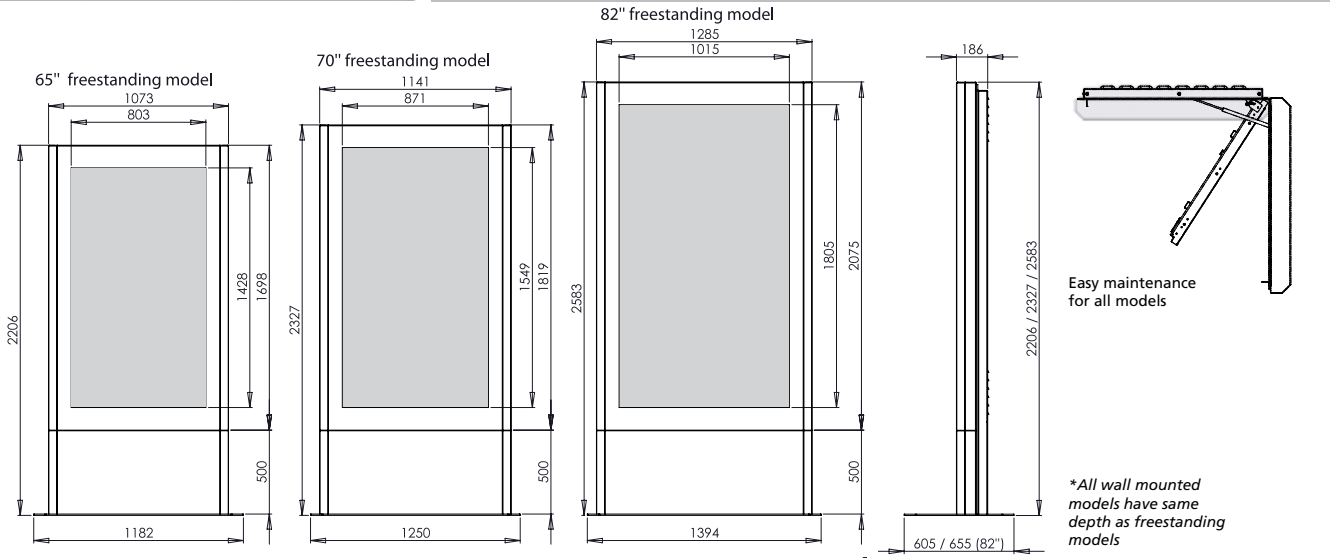

- ◆ Optional connectivity by WLAN, LAN and GPRS
- ◆ Industrial indoor TFT Lcd panel for 24/7 use, 365 days per year
- ◆ Full HD resolution 1920x1080 pc with 16,7 million colors
- ◆ Low frequency of maintenance activities
- ◆ Extremely reliable
- ◆ Tempered safety glass
- ◆ Robust aluminum housing
- ◆ Thermal management: with safety shut down
- ◆ Door equipped with 2 safety locks and 2 gas springs

Robust aluminum housing, powder coated colored on your request in every RAL colour. Custom designs and thinner wall mounted models upon request.

ROTAPANEL INTERNATIONAL BV
 Plutoweg 2, 8938 AB Leeuwarden
 NEDERLAND
 Phone: +31 58-288-00-00
 Fax: +31 58-288-2830 Email: info@rotapanel.com

ROTAPANEL NORTH AMERICA INC.
 1908 Mockingbird, Suite B
 Paragould, AR 72450, USA
 Phone: (001) 888-679-9886
 Fax: (001) 870-236-4442 Email: usa@rotapanel.com

ROTAPANEL

www.rotapanel.com

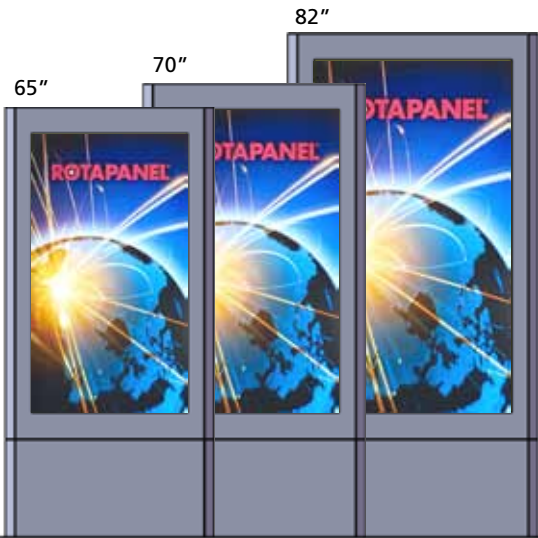

General information professional TFT LCD indoor advertising displays

Display	65" Full HD	70" Full HD	82" Full HD
Diagonal Size	65" diagonal	70" diagonal	82" diagonal
Aspect Ratio	9:16 portrait	9:16 portrait	9:16 portrait
Resolution	1080x1920 pixels	1080x1920 pixels	1080x1920 pixels
Brightness	700 cd/m ² (typical)	600 cd/m ² (typical)	600 cd/m ² (typical)
Contrast Ratio	2,500:1 (typical)	2,000:1 (typical)	2,000:1 (typical)
Number of colors	16,7 Mil	16,7 Mil	16,7 Mil
Response time	8 ms	8 ms	8 ms
Viewing angle	178° in all directions	178° in all directions	178° in all directions
Display Area (portrait)	2' 7-5/8" x 4' 8-1/4" (WxH)	2' 10-5/16" x 5' 1" (WxH)	3' 3-15/16" x 5' 11-1/16" (WxH)
Backlight type	CCFL	CCFL	CCFL
Vandal proof housing:			
Cabinet	aluminium	aluminium	aluminium
Surface treatment	powder coated	powder coated	powder coated
Glass	1/4" tempered safety glass	1/4" tempered safety glass	1/4" tempered safety glass
Weight wall model	269 Pound	291 Pound	357 Pound
Weight single sided freestanding model	441 Pound	463 Pound	551 Pound
Operating Parameters:			
Operating Temperature	32°F to 86°F / 95°F (optional)	32°F to 86°F / 95°F (optional)	32°F to 86°F / 95°F (optional)
Power Supply	AC 100-240 V, 50/60 Hz	AC 100-240 V, 50/60 Hz	AC 100-240 V, 50/60 Hz
Power Consumption	550 Watt	650 Watt	1000 Watt

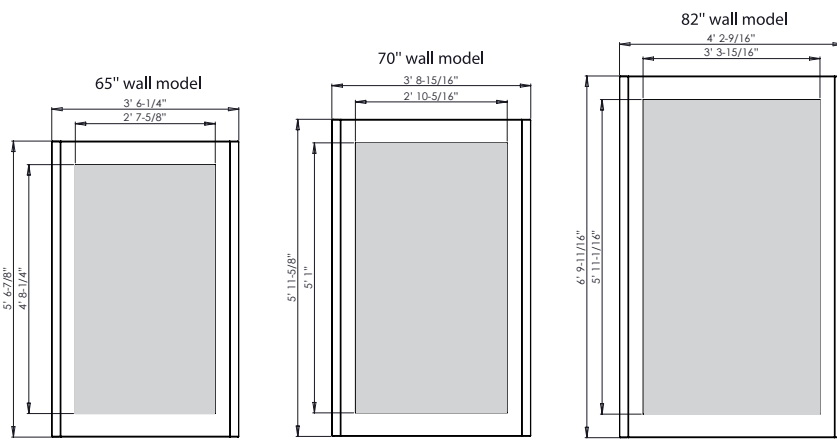
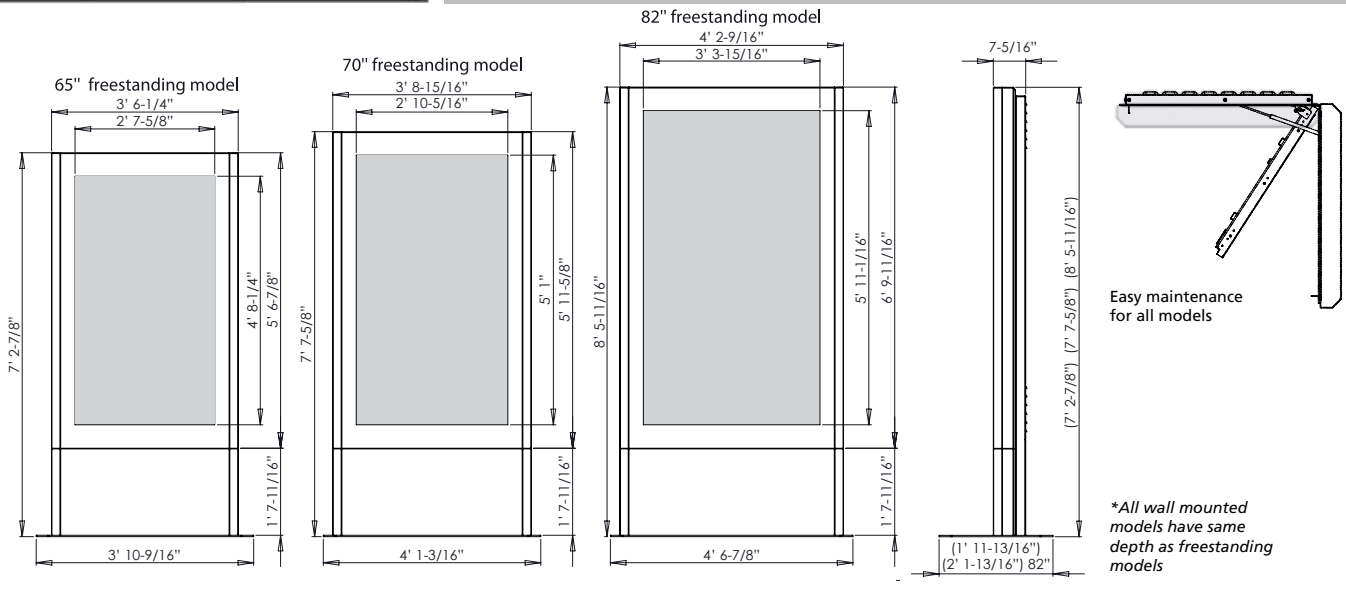

- ◆ Optional connectivity by WLAN, LAN and GPRS
- ◆ Industrial indoor TFT lcd panel for 24/7 use, 365 days per year
- ◆ Full HD resolution 1920x1080 pc with 16,7 million colors
- ◆ Low frequency of maintenance activities
- ◆ Extremely reliable
- ◆ Tempered safety glass
- ◆ Robust aluminum housing
- ◆ Thermal management: with safety shut down
- ◆ Door equipped with 2 safety locks and 2 gas springs

ROTAPANEL INTERNATIONAL BV
 Plutoweg 2, 8938 AB Leeuwarden
 NEDERLAND
 Phone: +31 58-288-00-00
 Fax: +31 58-288-2830 Email: info@rotapanel.com

ROTAPANEL NORTH AMERICA INC.
 1908 Mockingbird, Suite B
 Paragould, AR 72450, USA
 Phone: (001) 888-679-9886
 Fax: (001) 870-236-4442 Email: usa@rotapanel.com